

FUN DAY

BOY SCOUTS OF CANADA • GREATER TORONTO REGION
316 BLOOR ST. W., TORONTO, M5S-1W5 • PHONE 925-3425



May 29

York University

IN CASE OF RAIN
(OR IF IN DOUBT)
LISTEN TO
CFRB
AT
7:30 a.m. - 7:45 a.m.
ON
SATURDAY, MAY 29TH
FOR INSTRUCTIONS



SPECIAL NOTES

GYM EVENTS

EVERYONE PARTICIPATING IN EVENTS HELD IN THE GYM MUST WEAR CLEAN GYM SHOES OR BE IN STOCKING FEET. NO STREET SHOES WILL BE PERMITTED.

MASK & FIN SWIM

EVERYONE WISHING TO PARTICIPATE IN THIS EVENT MUST PREREGISTER ON AN INDIVIDUAL BASIS. THIS CAN BE DONE IN THE MAIN REGISTRATION AREA ON A FIRST COME BASIS STARTING AT 8:30 AM.



PROGRAM



6:00 a.m. to 9:00 a.m.	SETTING UP AT ALL AREAS	
8:30 a.m. to 9:30 a.m.	REGISTRATION	ARENA
9:30 a.m.	OPENING CEREMONIES	ARENA
9:45 a.m. to 5:00 p.m.	CANADA FITNESS AWARD	TRACK FIELD
9:45 a.m. to 5:00 p.m.	HANDICAPPED EVENTS POLICE BICYCLE RODEO	S.W. PARKING LOT
9:45 a.m. to 5:00 p.m.	FIELD SPORTS (OUTDOORS) - BALL TOSS - FIELD HOCKEY - ONE-ARM POLO - MONSTER BALL - BASKET BALL CHALLENGE - VOLLEYBALL CHALLENGE - BADMINTON MATCH - 3-LEGGED SOCCER - DONKEY BASEBALL - JOUSTING - BASKET SHOOTING	PLAYING FIELDS
9:45 a.m. to 5:00 p.m.	BACK WOODS GAMES - ORIENTEERING - OBSTACLE COURSE - LOG ROLLING - LOG SAWING - ROPE BRIDGES - BO'SUN'S CHAIR - MONKEY BRIDGES - BUCKING BRONC RIDES - FIRE BY FRICTION	RIVER VALLEY FLATS
9:45 a.m. to 5:00 p.m.	FIELD GAMES - RELAY RACES - 3-LEGGED RACES - HURDLES - BROAD JUMPING - SKIPPING - STILT WALKING - DISCUS THROWING - SHOT-PUTTING - BALL TOSS - PLANK WALK - MARBLE RELAY - SCOUTS' PACE	OPEN FIELD SOUTH OF TAIT McKENZIE BUILDING
9:45 a.m. to 5:00 p.m.	SCOUTCRAFT - CHARIOT RACES - FLAG POLE RAISING - KNOTTING RELAY - KITE FLYING - TENT PITCHING - SNOWSHOE RELAY - LIFELINE TOSS	SOUTH SIDE SHOREHAM DRIVE
9:45 a.m. to 5:00 p.m.	CANOE SLALOM COURSE	POND
9:00 a.m. to 5:30 p.m.	RED CROSS WATER SAFETY SWIM SESSION MASK & FIN SWIM INSTRUCTION	SWIMMING POOL
9:45 a.m. to 5:00 p.m.	INDOOR GAMES - QUOIT ROUNDERS - PUSHBALL - TIN CAN CRICKET - MURDER BALL - VOLLEYBALL - BASKET BALL - BADMINTON - COSMO HOCKEY - BACKYARD TENNIS - BORDEN BALL - SUPERSTAR OBSTACLE COURSE	LARGE GYM
10:00 a.m. to 4:00 p.m.	BEAVEREE - FULL ACTIVITY PROGRAM FOR BEAVERS	NORTH FIELD
5:00 p.m. to 7:00 p.m.	OX ROAST - FREE OXBURGERS (AS FAR AS THEY GO ROUND)	PIONEER VILLAGE
7:00 p.m.	CLOSING CEREMONIES	PIONEER VILLAGE
7:00 p.m. to 9:00 p.m.	CAMP FIRE AND ENTERTAINMENT	PIONEER VILLAGE
9:00 p.m.	CLEAN UP AND CHECK OUT. REMOVE ALL EQUIPMENT	ALL AREAS

EVENTS

NAME OF EVENT	FOR	BRING OWN EQUIPMENT	TEAM OR INDIVIDUAL
CANADA FITNESS AWARD	C-S-V	YES	I
HANDICAPPED EVENTS	B-C-S-V-R		
BICYCLE RODEO	C-S		I
FIELD SPORTS			
- Ball Toss	C		I
- Field Hockey	S-V-R	YES	T
- One-Arm Polo	S		T
- Basketball Challenge	S		T
- Volleyball Challenge	V-R		T
- Pushball	C		T
- Monsterball	S-V-R		T
- Basket Shooting	C		I
- Badminton Match	C		T
- 3-legged Soccer	S		T
- Donkey Baseball	FAMILY		T
- Jousting	S		I
BACKWOODS GAMES			
- Orienteering	S-V-R-FAMILY	YES	I
- Obstacle Course	S-V-R		I
- Log Rolling	S-V-R	YES	I
- Log Sawing	C-S-V-R		T
- Rope Bridge	C-S-V-R-FAMILY		I
- Bo'sun's Chair	C-S-V-R-FAMILY		I
- Monkey Bridge	C-S-V-R-FAMILY		I
- Bucking Bronc Ride	C-S-V-R		I

NAME OF EVENT	FOR	BRING OWN EQUIPMENT	TEAM OR INDIVIDUAL
- Fire by Friction	S-V-R		I
CANOE SLALOM COURSE	S-V-R	YES	I
FIELD GAMES			
- Scout's Pace	S-V-R		I
- Marble Relay	C		T
- Plank Walk	C		I
- Ball Toss	C		I
- Discus Throw	C		I
- Stilt Walking	S-V		I
- Skipping	C-S		I
- Broad Jump	C-S		I
- Hurdles	S		I
- Three-Legged Race	S		I
- Relay Race	C		T
- Sack Race	C-S		I
- Shot Put	C		I
SCOUTCRAFT			
- Chariot Race	S-V		T
- Tent Raising	S-V		T
- Flag Pole Raising	S-V		T
- Knotting Relay	C-S		T
- Kite Flying	B-C-S		I
- Lifeline Toss	C-S-V		I
- Snow Shoe Race	S-V		I
MASK & FIN SWIM INSTRUCTION	S-V	YES	I
WATER SAFETY SWIM SESSION	C-S-V	YES	I

NAME OF EVENT	FOR	BRING OWN EQUIPMENT	TEAM OR INDIVIDUAL
INDOOR GAMES			
- Volleyball	C		T
- Basketball	S-V		T
- Badminton	C-S-V		I
- Cosmo Hockey	C		T
- Backyard Tennis	C		I
- Borden Ball	S-V		T
- Quoit Rounders	C-S		T
- Pushball	S-V		T
- Tin Can Cricket	S		T
- Murderball	C		T
- Superstar Obstacle Course	C-S-V		I
BEAVEREE			



Instructions & Information

WHAT

1. What It Is - Fun Day is the gala climax to the "Scoutsport '76" program - a terrific day of Scoutcraft, sporting events, and fun games. All boys will have an opportunity of participating in a tremendous variety of events. This is not just for the seasoned athlete but for every boy in every Scouting group in Metropolitan Toronto. Plans are being made to accommodate 6000 boys and their families. It will be a largest "Scouts Toronto" gathering in over 10 years. Be a part of it.

WHERE

2. Where It Is - The setting for Fun Day will be the north-west campus of York University (including the Tait-Mackenzie Building which has the pool and gym facilities) and the Black Creek Valley south of Pioneer Village. The evening campfire and entertainment program will take part in the flats of Pioneer Village. See map enclosed for the complete lay-out.

WHEN

3. When It Is - Fun Day will take place from 9:00 a.m. until 9:00 p.m. on Saturday May 29, 1976. Note the information inside the back page of this booklet for alternate arrangements.

WHO

4. Who May Participate - Every member of the Scouting family - Beavers, Cubs, Scouts, Venturers, Rovers and their families may take part in the events noted under the various sections.

ETC.

5. Registration - To speed up the registration of your group please fill in the registration form included in this booklet and mail it or take it to Scout House by May 8th. On Fun Day your registration will be waiting for you at the Field House (see map for location). Your crests and all necessary information will be ready for your group. Please have one person from your group "check in" to pick up your Section's registration package. This package will contain a) a map, b) crests paid for, c) beads and shoe laces, d) any program updating, e) ox-burger tickets for those registered.
6. Committee Headquarters for Fun Day - Will be in the Rothmans Public Service Van located beside the Field House.
7. Things To Do - There will be an all-day program of swimming, canoeing, campcraft skills, pioneering, Canada Fitness Awards' Tests, field games, gym activities, etc. The full program is detailed in the following pages.
8. Cost - An entry fee \$1.50 per person for which you receive a great day's fun, mementos of each event a barbecued ox-burger and a crest to boot. This entry fee is for all boys and leaders wishing to obtain a crest and to take part in the day's program.

ABOUT THE PROGRAM

9. Program Notes -

A. Opening Ceremonies - The opening ceremonies will take place adjacent to the Field House at 9:30 a.m. It is hoped to have celebrities from the sports world at the opening ceremonies and during the day for the boys to meet, be photographed with, and obtain their autograph.

B. Individual and Team Events - A number of events are ideally suited for individual boys - others lend themselves to team participation. But with one or two exceptions all events may be entered by anyone whether they come as an individual or as a team (Six or Patrol). Events like cross-cut sawing, log rolling and kite flying are individual events - but there is no reason why every boy in the group cannot participate; they simply do it one at a time.

Team-style events like basketball, soccer and monster ball can be entered by a natural team (Six or Patrol) that is the whole team may come from the same "home group" or they can be in a group of individuals who have banded together to form a "pick up" team for that particular event.

Due to expectant demands, it is hoped that boys will not be "greedy" by participating in a popular event several times, when others who have not had the opportunity to enter for the first time are waiting in line.

C. Equipment And Supplies - All games' equipment and supplies, unless otherwise noted, will be provided by the Committee. Personal equipment, old clothing, swim trunks, towels, gloves, uniform, snorkel, mask & fin, compasses, string for kites, etc is the responsibility of the individual. These items will not be supplied.

D. Adult Supervision - It is suggested that each Six or Patrol be assigned an adult who will be responsible for their conduct and to assist with their entering events. The adults will also act as security for personal effects (hats, jackets, neckerchiefs etc.) during the events. Some adults may be asked to assist the staff with timing, score keeping, etc., during the event in which their boys are participating.

E. Awards System - The crest shown on the inside cover of this booklet will be issued to all who register. For each event a boy participates in, a specially marked bead will be issued at the conclusion of the event. Shoe laces for the beads and a registration bead will be issued at the check-in counter. These will be issued on basis of registration forms submitted prior to Fun Day.

F. Closing Ceremonies - The closing ceremonies will be held in Pioneer Village in conjunction with a giant camp fire, hootnanny and entertainment program being lined up for approximately 7:00 p.m. - 9:00 p.m. Again, it is hoped to have some personalities from the sports world present for the closing ceremonies.



G. Ox-Burgers - Enclosed with your registration kit will be a ticket for an ox-burger which will be given free to each person, from approximately 6:00 p.m. This can be an after supper "tied-you-over" snack until the campfire begins at about 7:00 p.m. The ox-burgers will be distributed to as many people as possible as long as they last.

H. Handicapped Scouts - A number of events especially keyed to the capabilities of our physically and mentally handicapped boys are being run in the south-west parking lot (see map for location). However, with the exception of the water events - swimming and canoeing - our handicapped members are most welcome to enter any event advisable by their Scouter. All handicapped groups will complete the registration form enclosed.

Vehicles belonging to members of the handicapped groups will be allowed to park in the south lot adjacent to their games area. Please ask the Security Group for directions. Special parking stickers are available on registration. Please note on your registration form the number desired.

I. Beavers - A special program for Beavers has been established. Please read the instructions in the Beaver section of this booklet. Due to the age of Beavers, their formal program is shorter than the full day. They will be welcome to stay for the evening campfire and entertainment program. Special parking adjacent to the Beaver program area is provided. Please note the map. Ask the Security Group for parking area directions. Special parking stickers are available on registration. Beavers will complete the regular registration form enclosed.



J. Special Note - All participants in the canoe slalom course and the mask and fin swimming must have proof of having passed the Scout Silver Stage Swimming Badge - or - Intermediate Level Red Cross, prior to entry. Encourage your boys to earn these awards so that they can participate in these two events.

K. Badge Tests - A number of badge test units can be completed at Fun Day. Scouters should look over the program for items which fit their boys' badge testing needs. Be prepared to consider their eligibility to pass tests during their participation in the various events.

SERVICES



NOTE

10. Services -

A. Parking - Ample parking is available. Entry to the campus is south from Steeles Ave. by Thompson Blvd., just east of Jane St. - or enter by Keele St. to the parking lots at the east end of the Campus area. Please follow the instructions of the Scout Security Group to the parking locations. You may find you have to walk a considerable distance to the events' area as most parking is east of the University buildings.

NOTE: Do not use parking lots at Pioneer Village as they are open for regular business on that day.

B. Public Transit - Public transportation is available using either the Jane or Steeles West buses. Inquire from the T.T.C. information service - 484-4544 - as to the best route for your group to take.

C. Meals - No meals will be supplied. Each person must come self-contained. A number of picnic tables will be available at Pioneer Village - otherwise make your own meal arrangements where you wish. No open fires are permitted, but camp stoves are allowed in designated areas provided they are off the ground. It is hoped to have a snack service available adjacent to Pioneer Village.

D. Garbage - Please use the garbage containers provided for your refuse. Remember the Scout Camp Motto - "leave nothing behind, only your thanks". We must pay to have the grounds cleaned after our events, therefore your help is solicited to make sure that this cleaning is at a minimum, thus keeping our costs down.

**PLEASE
USE
THEM**



E. Security - A special Scout Security Group will be responsible for security on the site. These people will be wearing orange coloured "hard hats", with Scoutsport stickers on the front. Please assist them to do their job - they are volunteers trying to help you to have a good day.

A member of the Security Group will be in each main activity area. If any problem arises ask them for assistance - they will ensure that you are given whatever help you may require. Each one will be equipped with a two-way radio to maintain communication with Headquarters' Van.

The main Security Base will be at Headquarters' site. Note map for location.

Any person who is sick or injured should report immediately to the nearest Security member. He will ensure that whatever help is necessary will be obtained. It is anticipated that the St. John Ambulance Association will have a member present and a doctor will be on site.

F. Lost and Found Equipment - Should be reported to the Security base. Lost or found children should be reported to the nearest member of the Security Group or the Headquarters' Van.

G. Personal Equipment Security - Each Section should arrange for whatever security is necessary to look after the personal belongings of their boys. There will be no checking facilities. Leaders should encourage their boys to have all pieces of clothing and equipment identified with a tag giving name, address, and group number. Remember we expect over 6000 people to attend. Lost or found articles should be reported or taken to the Headquarters' Van.

11. Pioneer Village - The Village is open on regular hours at regular rates for groups to enter under adult supervision. Groups are encouraged to take advantage of the day to organize a tour for their boys to see a portion of our Canadian heritage.
PLEASE DO NOT USE THE PIONEER VILLAGE PARKING LOT.

Fun Day Booklet - This booklet is being sent to all Beaver Leaders, Cubmasters, Troop Scouters, Venturer Advisors, Rover Advisors and Group Committee Chairmen. If you received the booklet and are not currently active or registered with your Section, please pass it on to the person responsible, so that plans can be made for your Section to enter. Note that registration is by Section and not by Group. It is therefore important that registration forms be completed properly.

Please be advised that any amendment, deletion or changes to this booklet will be made by a notation in the registration package which you pick up on Fun Day.



Canada Fitness Award

for Cub, Scout, Venturer

The objective of the Canada Fitness Award is to promote fitness and health in Canadian youth. This is achieved through a stimulating, challenging and progressively more demanding program of physical testing. We hope you have been practising at your weekly meetings. So come out now to get your awards.

The Award is based on six fitness-performance tests; each with a specific purpose. These are -

50-yard run	for speed
speed sit ups	for strength and endurance of abdominal muscles
flexed arm hang	for arm and shoulder girdle strength
shuttle run	for speed and agility
standing long jumps	muscle power of leg extensors
300-yard run	for cardiovascular efficiency

Crests are awarded on the basis of achievement compared to the age of the boy. The level he reaches in each test determines the award earned - bronze, silver, gold or the award of excellence.

On "FUN DAY" every boy from 7 to 17 will have the opportunity to participate in a testing program and earn the appropriate awards. Crests earned will be presented immediately upon completion of the test.

Boys interested in participating in the Canada Fitness program need only come to the test area - see map for exact location.

EQUIPMENT NEEDED

Each participant should wear soft-soled shoes (gym shoes, track shoes, joggers, etc.), and loose clothing that will permit fast action.

CANADA FITNESS AWARD TESTING STATIONS

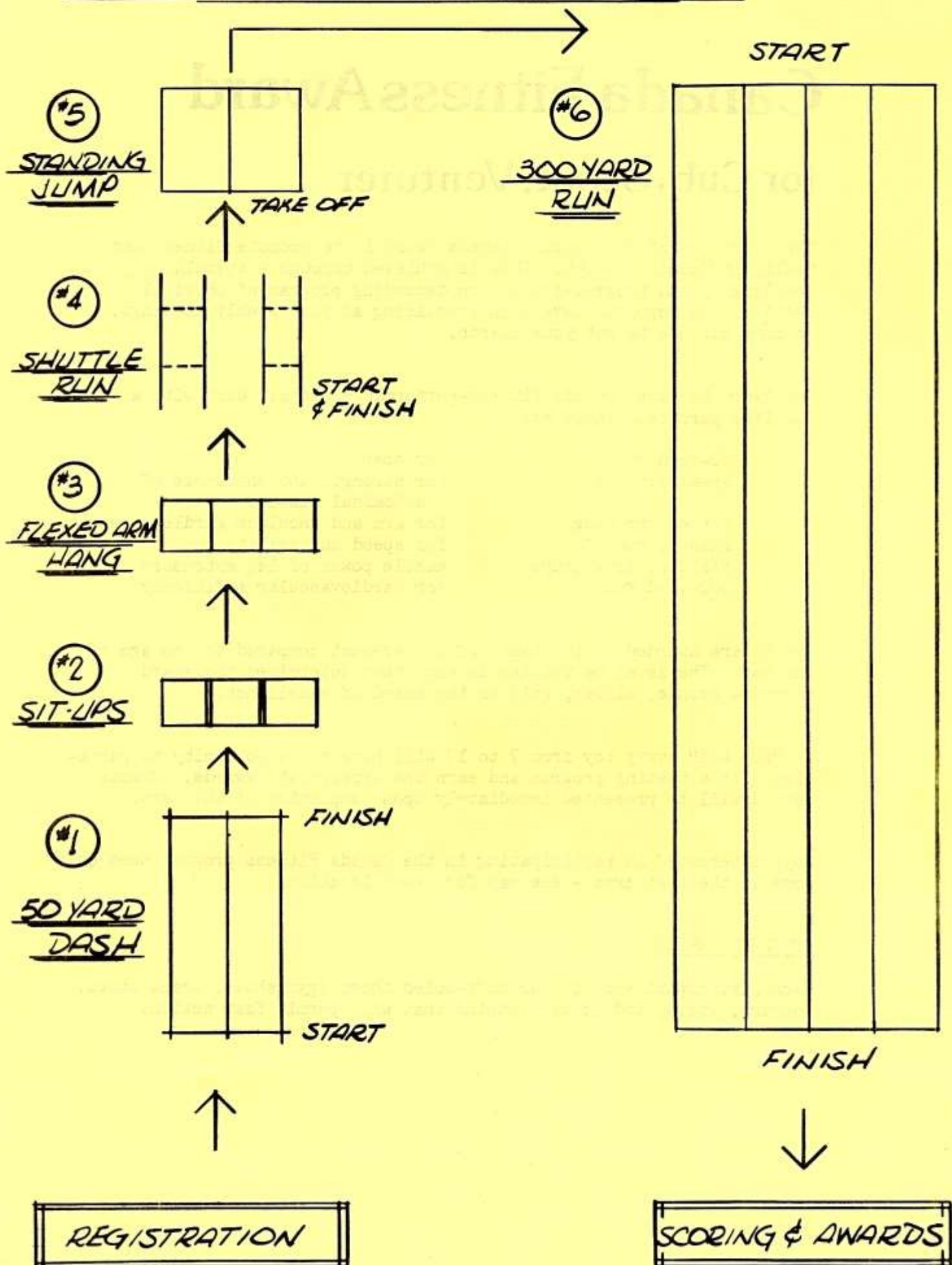

Bicycle Rodeo

**cub
scout**

A Bicycle Rodeo will be set up in the parking lot at the South end of the York University Campus, adjacent to the handicapped area.

The Rodeo will operate in accordance with the Metropolitan Toronto Police Bicycle Safety Program.

Check the Cub Handbook - Red Star requirement number 12 for safety details on bicycle operation or Canadian Scout Handbook - Safety Badge, Silver stage and the Safety & Emergencies Section, for bicycle safety procedures and rules.

Bicycles will be supplied courtesy of the Metropolitan Toronto Police Department. A short safety test on rules of the road is required in conjunction with the skill test on riding the bicycle.

Take time at a Pack or Troop meeting to review the above pages of the Handbook with your boys before Fun Day.

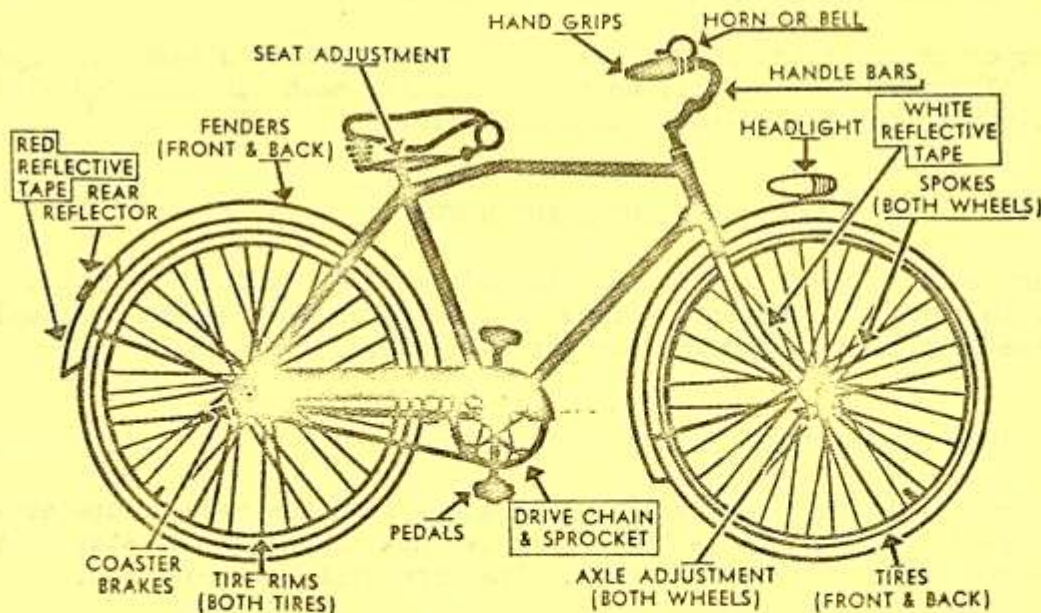

BACKWOODS GAMES

ROPE PIONEERING - FOR CUBS, SCOUTS, VENTURERS AND FAMILIES

There will be three events in this group: a Bo'sun's chair ride, a 3-strand rope bridge and a 2-strand monkey bridge. Each person will be allowed to walk over the two bridges and then slide down the rope chair ride.

OBSTACLE COURSE - FOR SCOUTS, VENTURERS AND ROVERS

Individuals will run the course climbing over, through and under various obstacles. Challenge your buddy to a race and beat his time.

ORIENTEERING - SCOUTS, VENTURERS, ROVERS AND FAMILIES

This is a regulation orienteering course using Silva rules and compass. The course will be laid out in the river flats. Be prepared with proper clothing. Individuals can enter to challenge their skills in this exciting sport.

NOTE: Each participant must bring his own compass.

LOG ROLLING (BURLING) - FOR SCOUTS, VENTURERS AND ROVERS

This is a test for balance and timing. The idea is to put two boys on a log in the middle of a pond and then release the log. The last remaining boy on the log is the winner.

All those participating please bring old clothing and perhaps an old pair of running shoes (no spikes allowed) - the pond is pretty muddy.

LOG SAWING - FOR CUBS, SCOUTS, VENTURERS AND ROVERS

This is your opportunity to enter a two-man team and establish a best time for the day. Each slice off the log will be split in half, each part branded with a hot iron and given to the participants as a souvenir.

FIRE BY FRICTION - FOR SCOUTS, VENTURERS AND ROVERS

Each participant will be given a bow, spindle and notched board along with a supply of duff to form a birds nest. Times will be taken from start to actual open flame - the best time posted for the day will win.

BUCKING BRONC RIDE - FOR CUBS, SCOUTS AND VENTURERS

A ride will be set up in the lower valley land along side the rope bridge area and will be available for all to take a "ride" and see how long they can stay on the "horse". Entrants enter at their own risk. The ride will be supervised.

FIELD SPORTS

DONKEY BASEBALL - FOR CUBS AND FATHERS (PICK UP TEAMS)

Donkey baseball is played by 18 or more players on each team. Pick up teams can be set up. This is a good game to involve fathers and sons. The game uses regular baseball rules with a special bat and ball. As a player hits the ball, he must mount "horse style" his "donkey" (father), to run to the base. The out-fielders and basemen, can catch the ball, but must mount their "Donkey" to throw the ball. Game time is 5 innings.

FIELD HOCKEY - FOR SCOUTS, VENTURERS AND ROVERS (PATROLS)

Teams of six players can be lined up in your own Group. Be ready to register on site. Same rules as for floor hockey. It is played with a special plastic hockey stick and ball. Will be played outdoors on grass field. Equipment supplied. Bring own gloves if desired. Ten-minute game, in two five-minute periods.

BALL TOSS - FOR CUBS (INDIVIDUALS)

The player will be given six balls to throw. #1 ball is thrown into a pail set 10' from the start line, #2 ball into a pail set 15' and #3 ball into a pail set 20' out. Two shots per pail are allowed.

ONE ARM POLO - FOR SCOUTS (TEAMS)

Line up a team of 10 players. Challenge a neighbouring Troop. Come ready to play. Each player must play with one arm tied down or with one hand tied into his pocket. The participants line up as for a hockey game - a goalie, two defence men and three forwards. Each team will attempt to put the ball into the opposing team's net.

The ball is hit or pushed with the open hand - it cannot be kicked! There will be no bouncing of the ball, tackling or knocking over of a player. Penalties will be assessed for rough play. Game time 10 minutes in two five-minute periods.

BASKET BALL CHALLENGE - FOR SCOUTS (PATROLS)

This is played with the same team size as for regular court basket ball except that it is on the open ground. The ball may be dribbled but this tends to be difficult so that passing is frequently used. Special baskets are used for goals. Game time 10 minutes, in two five-minute periods.

VOLLEYBALL CHALLENGE - FOR VENTURERS AND ROVERS (PATROLS)

Make up your team of 12 players and issue a challenge to a team or a group from your home area. There will be an outdoor volleyball court set up for this event. Regulation rules will be played. Game time 10 minutes in two five-minute periods.

PUSHBALL - FOR CUBS (TEAMS)

Make up a team at home and be prepared to register on arrival. This is a team game using ten members per team. The ball is pushed by hand; a goal is scored when the ball is pushed over the opposing team's goal line. Kicking of the ball is not permitted. Game time 10 minutes in two five-minute periods.

MONSTERBALL - FOR SCOUTS, VENTURERS AND ROVERS.

The game is played with a 4' diameter ball. Unlike pushball, the Monsterball may be picked up and carried by a team (that is if the other team will let them!). Team consists of 15 players. Time limit five minutes or first score wins.

BASKET SHOOTING - FOR CUBS (INDIVIDUALS)

Stand on the starting line and toss a basket ball over a six-foot high obstacle and into a plastic garbage pail. Three shots per person.

BADMINTON MATCH - FOR CUBS (SIX GAME)

Line up your teams in challenge matches and be prepared to submit entries. Six boys per team. The teams are set up on either side of the net. Each boy is provided with a paddle. Points are scored as for badminton. Game time 10 minutes, 2 five-minute periods.

THREE LEGGED SOCCER - FOR SCOUTS (TEAMS)

The participants are organized into two teams of 12 players. The Scouts pair up together and tie their inside legs together. One pair on each team acts as a goalie. The ball is placed at centre field, the teams then try to kick the ball into the opposing team's net. Game time 10 minutes, 2 five-minute periods.

JOUSTING - FOR SCOUTS (INDIVIDUAL)

The two opponents face each other on a rocking plank placed on a log. Each player has a Scout stave and must use strength and skill to push opponent off the plank - best two out of three falls wins.

500 METRE CANOE COURSE

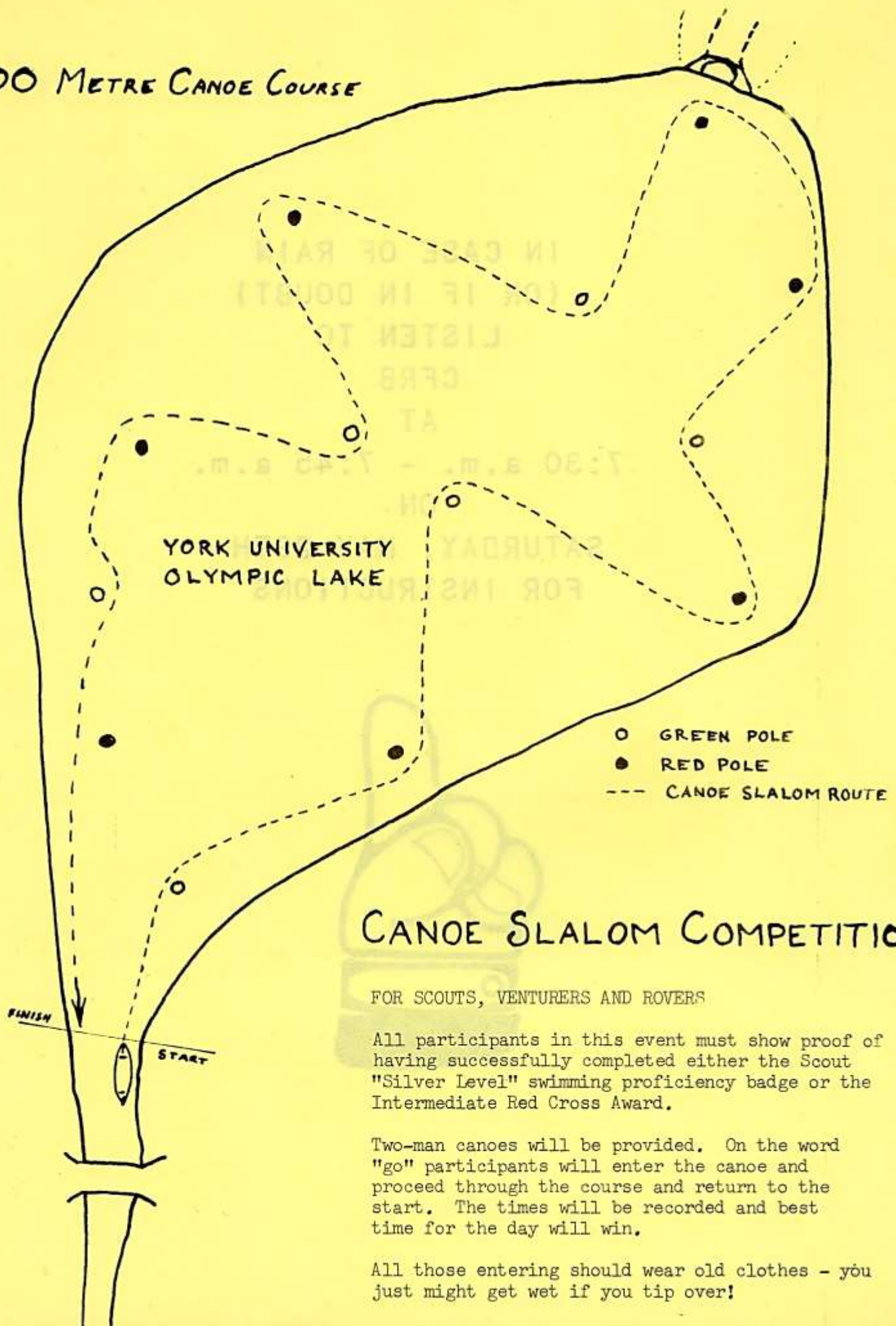

CANOE SLALOM COMPETITION

FOR SCOUTS, VENTURERS AND ROVERS

All participants in this event must show proof of having successfully completed either the Scout "Silver Level" swimming proficiency badge or the Intermediate Red Cross Award.

Two-man canoes will be provided. On the word "go" participants will enter the canoe and proceed through the course and return to the start. The times will be recorded and best time for the day will win.

All those entering should wear old clothes - you just might get wet if you tip over!

IN CASE OF RAIN
(OR IF IN DOUBT)
LISTEN TO
CFRB
AT
7:30 a.m. - 7:45 a.m.
ON
SATURDAY, MAY 29TH
FOR INSTRUCTIONS



FIELD GAMES

SCOUT'S PACE - FOR SCOUTS, VENTURERS AND ROVERS

Using "Scout's Pace" - that is walking and jogging alternately for short spells of fifty paces - cover the set course of one mile. There is an optimum time of 12 minutes for this event but participation is more important than timing. Times to be posted.

MARBLE RELAY - FOR CUBS

This is run with 6 boys per team. The first boy runs 15' from the starting line and picks up a marble with his bare toes and carries it back to the starting line. Each boy in turn does this until all 6 have run. First team to complete wins.

PLANK WALK - FOR CUBS

A 20-foot plank is rigged with its two-inch width uppermost. Each entrant will attempt to cross the beam - the more adventuresome will run over.

BALL TOSS - FOR CUBS

A regulation soft ball is thrown for distance and accuracy. Distance to be posted.

DISCUS THROW - FOR CUBS

Each player to throw a discus for distance and accuracy. Length of throw to be posted.

STILT WALKING - FOR SCOUTS AND VENTURERS

Each competitor will line up on the starting line with a pair of stilts in front of him. On the whistle each will get up on his stilts and proceed through an obstacle course. The obstacles consist of tires (which are walked over) logs (which are jumped over) and pylons (which are zig zagged around).

SKIPPING - FOR CUBS AND SCOUTS

Each participant is provided with a skipping rope and he must skip 25 times each with both feet frontwards, both feet backwards and alternate feet frontwards.

BROAD JUMP - FOR CUBS AND SCOUTS

There will be a regulation broad jump pit - objective is maximum jump depending on age. Jumps to be posted.

HURDLES - FOR SCOUTS

This will be a regularly styled hurdle course. The individual can run the course against the clock for his own satisfaction. Times to be posted.

THREE-LEGGED RACE - FOR SCOUTS

This is a variation on the old three legged race - along with the usual tying of inside legs together we have introduced a series of obstacles as well.

RELAY RACE - FOR CUBS

There will be a series of relay races that either natural or 'pick up' sixes can enter. Get your teams lined up now to enter.

SACK RACE - FOR CUBS AND SCOUTS

Each boy puts his legs into a sack. The winner is the first person back after completing the course. A different course will be used for Cubs and Scouts.

SHOT PUT - FOR CUBS

Using a ball each entrant will 'put' the ball for distance and accuracy. Distances to be posted.

INDOOR GAMES

RUNNING SHOES MUST BE WORN

A. "SUPERSTAR" OBSTACLE COURSE - FOR CUBS, SCOUTS AND VENTURERS

A system of obstacles set up, in the upper gym of the Tait McKenzie Physical Education building, much the same as the popular T.V. version of the Professional Athletes Superstar Competition. To involve stop watch competition of running, jumping, climbing, competing against time.
Running shoes and old clothes.

B. COSMO HOCKEY - FOR CUBS

Indoor road hockey played with plastic hockey sticks and puck. Six players on each team play at once using same rules as ice hockey. Group teams or pick up game.

C. PUSH BALL - FOR SCOUTS AND VENTURERS

This game is played while crawling on your hands and knees on the gym floor. Object of the game is to hit a volleyball into the opponent's net with your hands. Six players per team play at once, rules are much like ice hockey. Group teams or a pick up game. Old clothes needed.

D. BORDEN BALL - FOR SCOUTS AND VENTURERS

Fifteen players per team play at once using a basketball on a basketball court. Five players are on the court and with the remaining ten players per team lined up alternately along both sidelines. Floor players are only allowed 3 steps before passing the ball to another player either on the court or on the sidelines. To score you must sink a ball in the opponent's net. Group teams or pick up game.

E. MURDER BALL - FOR CUBS

Two teams line up on opposite sides of a gym facing each other lying on their stomachs. A volleyball is placed in the middle of the floor. When the whistle is blown each team charges for the ball. The object of the game is for one team to hit the opponents below the waist with the ball. Once a player has been hit he sits out until there is one player left. His team is then the winner. Game 10 minutes, 2 five-minute periods.

F. VOLLEYBALL - FOR CUBS

Using 9 players per team. A group team effort. Game 10 minutes, 2 five-minute periods.

G. BADMINTON - FOR CUBS, SCOUTS AND VENTURERS

Doubles or singles. Equipment supplied. An individual game.

H. QUIT ROUNDERS - FOR CUBS AND SCOUTS

Played by 9 players per team. 1 catcher and 8 fielders. Played with a quoit similar to a floor hockey ring. Baseball diamond set up in gym with a foul line running from 1st to 3rd base. Batter stands at home plate and throws quoit over foul line. If quoit is caught batter is out, if not caught batter runs around bases, 1st to home plate. He may keep running around the base until the quoit is thrown to the catcher and he yells stop. That batter scores the number of bases he has covered. Score is tallied like baseball. Group team game. Game 10 minutes, 2 five-minute periods.

I. TIN CAN CRICKET - FOR SCOUTS

Nine players on each team. 2 tin cans are placed one on top of the other about 20 yards apart. 2 batters from same team stand in front of each set of cans holding a baseball bat with the end of the bat in a circle in front of the cans. A pitcher from the other team rolls the ball on the floor towards the cans. Batter must attempt to hit the ball before it knocks over the cans. If cans fall batter is out. If batter hits the ball then the two batters must run and exchange places before the cans are knocked over by fielders retrieving the ball. The fielding team requires one pitcher at each set of cans and the rest are fielders. You score as in baseball. Game is 10 minutes, 2 five-minute periods.

J. BASKETBALL - FOR SCOUTS AND VENTURERS

Team of 5 players. Regulation game. 10 minutes, 2 five-minute periods.

K. BACKYARD TENNIS - FOR CUBS (INDIVIDUAL GAME)

Tennis ball is suspended on the end of a long rope and attached to a 10 foot pole. Two boys, one on each side of the pole use tennis paddles (not rackets) to attempt to knock the tennis ball to the top of the pole. The rope is connected to the pole by a coil. One boy attempts to knock the ball to the top of the pole while the other to the bottom. Whoever succeeds wins.

SCOUTCRAFT

1. CHARIOT RACE - FOR SCOUTS AND VENTURERS

Each team should construct a chariot or travois by lashing staves together. The chariot should be sufficiently sturdy for the rest of the patrol to drag one of its members on the chariot over a 50-yard course. Time limit to be noted and posted.

Skills required: Square and diagonal lashings.
Equipment will be provided. (See diagram attached)

2. TENT RAISING - FOR SCOUTS AND VENTURERS

Each team will pitch and strike a (1) wall tent, (2) lightweight tent. The patrol will be timed separately for the pitching and striking. The tent must be pitched properly to the satisfaction of the Scouter in charge, tent pegs in line, guy lines square and poles straight. Time limit to be posted.

After striking the tent, it should be brushed off, rolled neatly and tied. Tent pegs to be cleaned.

Skills required: How to raise and lower a tent; how to make a guy line hitch. Tents, poles, pegs and mallets will be provided.

3. FLAG POLE RAISING - FOR SCOUTS AND VENTURERS

A team will construct a flag pole by lashing staves together, rig up a pulley and break a flag. The flag pole must be erected in the centre of a circle of 5 yards radius and during construction no member of the patrol may enter the circle. Time limit to be posted.

Skills required: Sheer lashings, how to roll a flag and attach it to the halyards and how to break the flag.
Staves, lashing rope, wedges, lines, pegs, pulley and flag will be provided.

4. KNOTTING RELAY - FOR CUBS AND SCOUTS

As a patrol or six in relay formation, each Cub or Scout will run up and tie a knot or make a hitch until all six lengths of rope are joined securely. The six knots will be: a clove hitch, a reef knot (2), a sheet bend (2), and a bowline. The bowline should be tied round the waist of the last member of the patrol or six.

Skills required: Knotting.
Ropes to be provided.

5. KITE FLYING - FOR BEAVERS, CUBS AND SCOUTS

Using your own materials or with the materials provided, construct and fly a kite. The kite must be kept airborne for at least 3 minutes.

Skills required: Kite making.

Plastic sheeting, light wood and twine will be provided. Bring your own string line.

6. LIFELINE TOSS - FOR CUBS, SCOUTS AND VENTURERS

Each member is to toss a 30-foot life line for distance and accuracy. There will be no weight on the rope. This is tougher than it sounds!

7. SNOW SHOE RACE - FOR SCOUTS AND VENTURERS

Each participant will be provided with a pair of "snowshoes" made with sandals nailed onto wood planks. The race is to cover the given course which will include various obstacles. Time to be posted.

CHARIOT RACE EQUIPMENT

For information on lashing - see Page 109 in Scout Handbook.

Materials Needed

- 2 Poles - 8' long 1½"-2" Diameter at Butt
- 1 Pole - 4' long 1½"-2" Diameter
- 1 Pole - 2' long 1½"-2" Diameter (Green Maple is Preferable)
- 5 Pieces - Rope 5' long 3/8" Manilla or Equivalent

- Team consists of 4 to 6 boys.
- Participants are required to assemble the chariot (as shown), and use it to carry one member of the team over a given course.
- If chariot falls apart during event, it must be repaired.
- At end of event, the chariot is disassembled and parts neatly stacked.

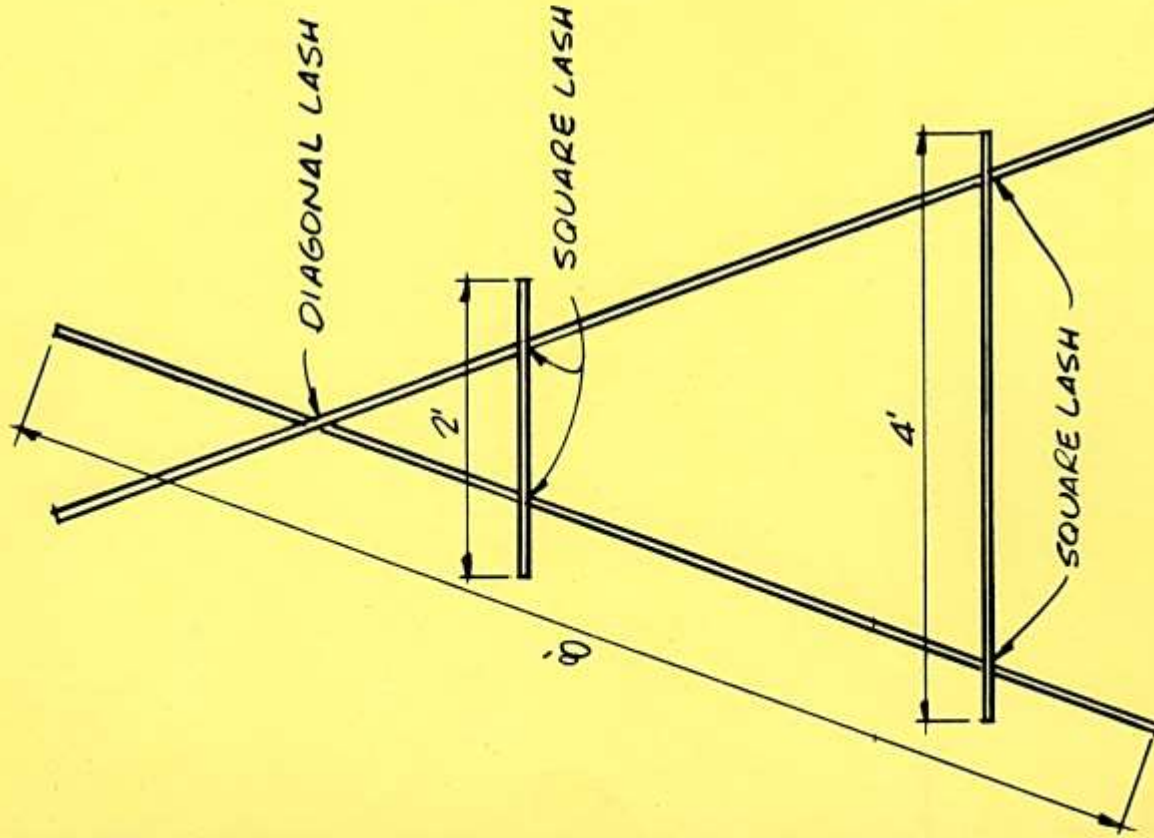

RED CROSS WATER SAFETY SWIM SESSION

The general swim program will consist of a talk session on water safety, a briefing on pool swim rules and a 30-minute free swim period in the pool. No diving will be permitted. It is estimated that it will take $1\frac{1}{2}$ hours to complete this event. Each person must bring his own bathing suit and towel. Each group must provide sufficient adult leadership to ensure proper decorum in the locker room.

All activity on the pool deck and in the water will be under the regulation of the pool life guards.

This program will run from 11:30 a.m. to 5:30 p.m. with a new shift entering the pool every half hour.

No pre-requisites are required - all Cubs, Scouts, Venturers and Rovers are invited.



RED CROSS WATER SAFETY SWIM SESSION

MASK AND FIN SWIM INSTRUCTION - FOR SCOUTS AND VENTURERS

Participants will be given an introduction into the sport of snorkelling. Instruction will be given in the selection, care and use of equipment; proper swim technique and the necessity of using the "buddy" system. It is not a lecture session but an active in-the-water program.

Pre-requisite - all participants must hold either the Scout "Silver Stage" swim badge or the Intermediate Red Cross Certificate.

- Each person to bring swim trunks and towels
- Each person must bring his own mask, snorkel and swim fins
- no previous experience in snorkelling is necessary.

To comply with health and safety regulations, this event must be operated in groups of not more than 40 boys. There is a time limit on the use of the pool for this event, therefore only four sessions can be accommodated, as follows:

1. 9:00 a.m. to 10:00 a.m.
2. 9:30 a.m. to 10:30 a.m.
3. 10:00 a.m. to 11:00 a.m.
4. 10:30 a.m. to 11:30 a.m.

In order to register your qualified boys for this exciting adventure, a pre-registration desk will be set up in the Arena beginning at 8:30 a.m. Spaces for each session will be allocated on a first-come basis.

MASK & FIN



BEAVEREE

A special area for the BEAVER segment of the FUN DAY program has been set aside immediately north of the FIELD HOUSE. The enclosed map of the ground shows where this is. The boys can go directly to this area while one leader registers the group.

Parking for cars belonging to BEAVER groups will be in a specially reserved part of the main lot. Please ask the Scouting security person - who will be wearing an orange hard hat - for directions.

The program starts at 1:00 p.m. and will finish at 4:00 p.m. Any group that wishes may stay later, have a look at what else is going on and participate in the campfire program which is scheduled for 7:00 p.m. in Pioneer Village. Perhaps groups might wish to have their members go home for supper and re-assemble later for the campfire. The choice is yours!

Pre-registration is by the enclosed form. Having this in early will make it easier for us to be prepared. When you arrive your registration kit will be ready - have one leader pick this up from the Registration area in the Field House. Please turn in a list of names of those attending from your Colony.

Each Colony must come self-contained; food and drinks are not supplied. A Tuck Shop service will be operating near Pioneer Village Area but this is a fair walk from the BEAVER Program Area.

Colonies are welcome to visit other program areas but because of the ages of Beavers they may not participate in these events. Every two Beavers must be accompanied by one adult - make sure that every boy is wearing a tag giving his name and group number.

Beaver program events will include an obstacle course, mini exercise program, bicycle rodeo, and an area for individual and group games.

Registration Form

FUN DAY



May 29

YES, We will be there

NO, Sorry we can't make it

Group Name & Number _____

Colony Pack Troop Company Crew

Leader in charge _____

PLEASE PRINT

Phone Number _____

Number of boys and adults attending at \$1.50 each _____
(One crest free to each person)

Cheque/Cash attached _____

(Cheques payable to "Boy Scouts Of Canada")

Beaver Car Stickers requested _____
(Only good 12 noon to 9 p.m.)

Handicapped car stickers requested _____
(Good for use 9:00 a.m. to 9:00 p.m.)

Pick up crests ordered at Field House, York University on Fun Day when you arrive.

Office use only

Number Crests ordered _____ Shoe laces & Beads _____

Issued by _____

Received by _____

NOTE:

1. If extra crests available will be sold on Fun Day only - 50¢ each.

2. Please return this form to:

Scoutsport Committee,
c/o 316 Bloor St. W.
Toronto, Ontario.
M5S 1W5

BEFORE MAY 15TH, 1976.